

3000+ HAPPY CUSTOMERS

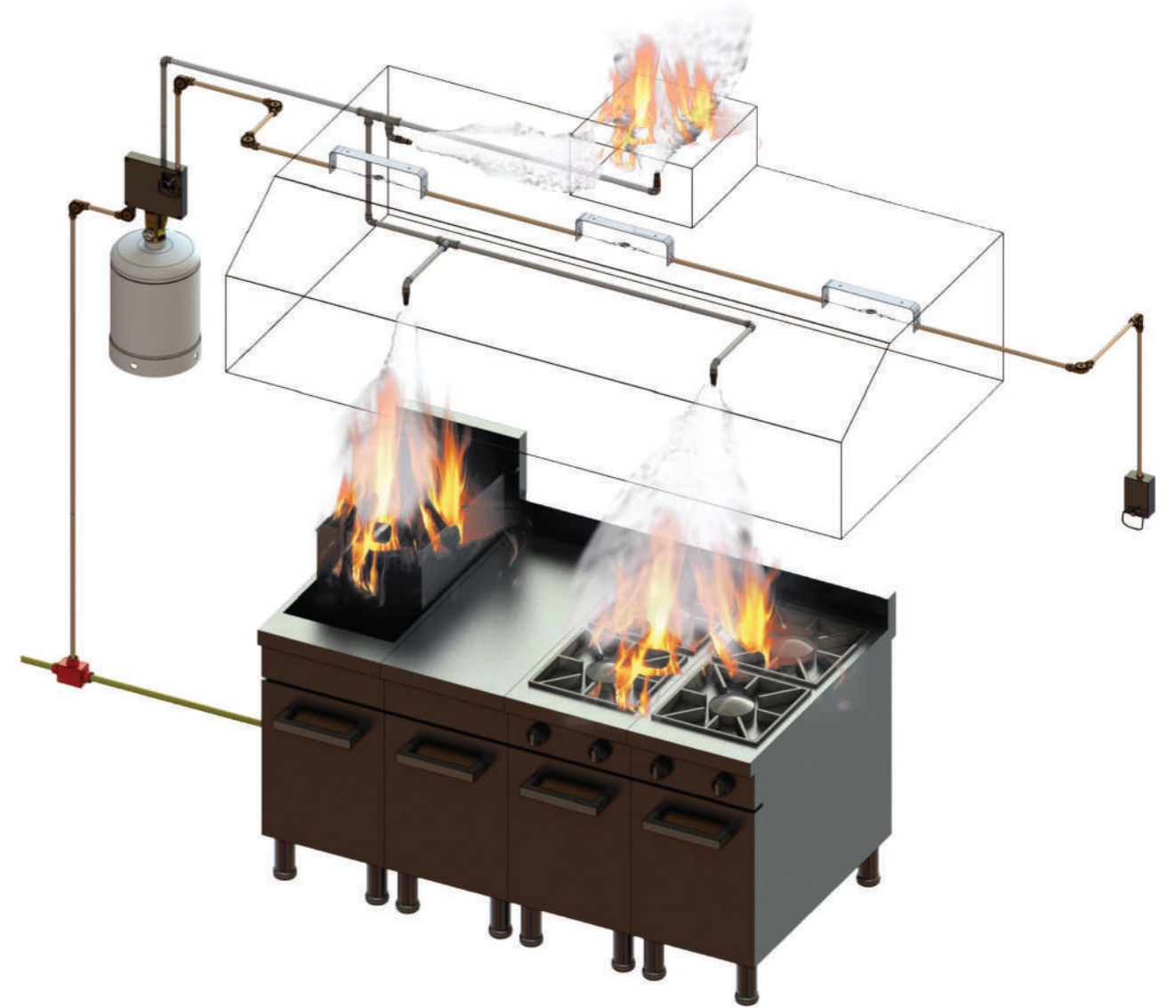

KITCHEN FIRE SUPPRESSION SYSTEMS



Kitchen Fire Suppression Systems • Compact Fire Suppression Systems • Clean Agent Fire Suppression Systems • CO2 Fire Suppression Systems

Defender Yangın Söndürme Sistemleri

ANTALYA T: +90 242 221 40 07 F: +90 242 259 28 88

İSTANBUL T: +90 216 348 49 58 F: +90 216 348 28 69

▶ info@defender.com.tr



Superior Products



Competitive Products



Fast Detection



Certified Product



Superior Products



Competitive Products



Fast Detection



Certified Product

▶ **Defender M Type System (Mechanical)**

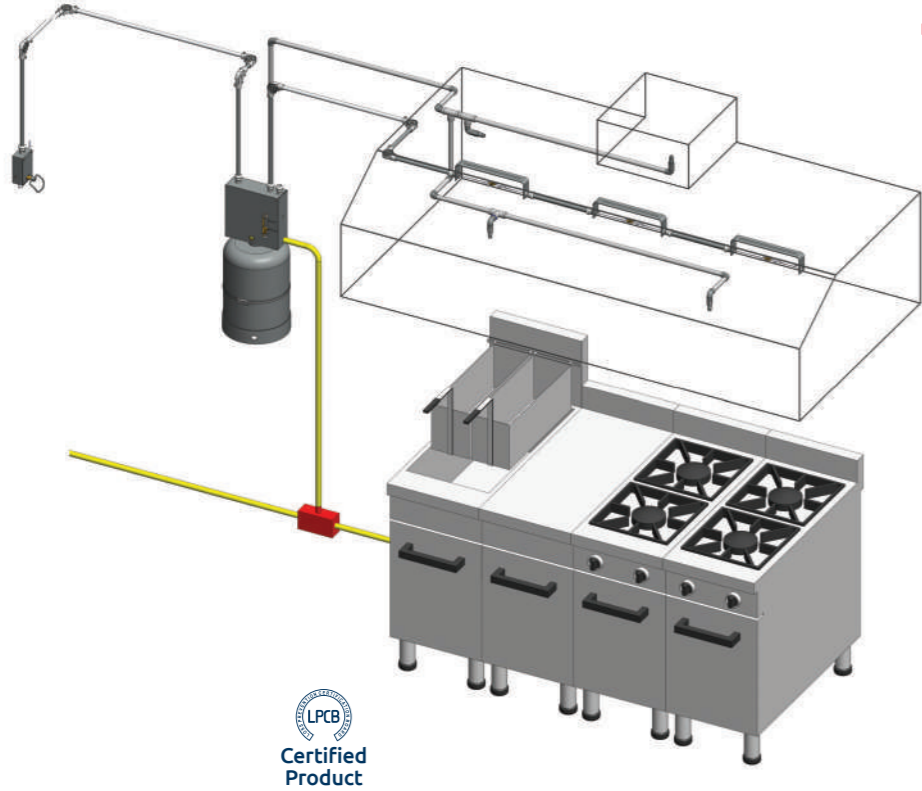

▶ **Defender P Type System (Pneumatic)**

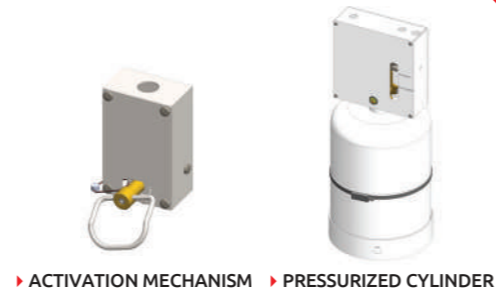
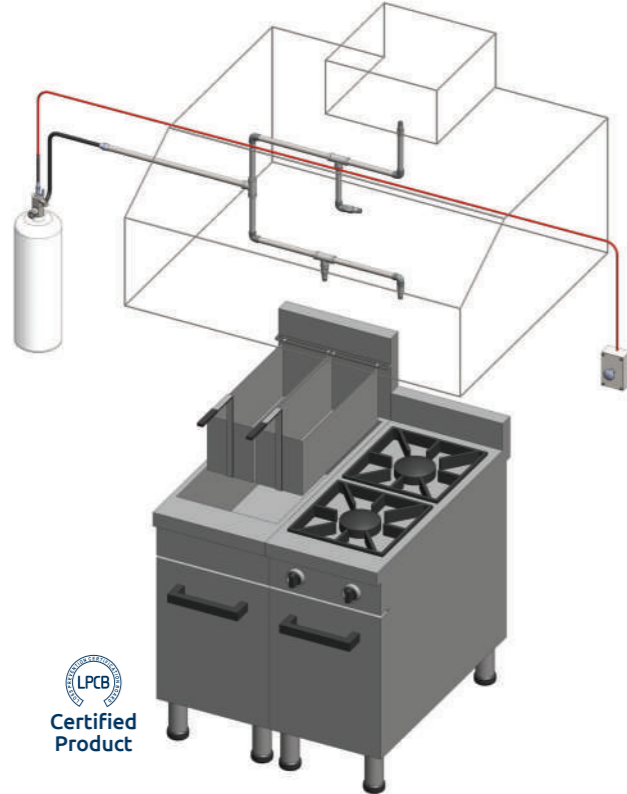

▶ ACTIVATION MECHANISM ▶ PRESSURIZED CYLINDER



▶ NOZZLE ▶ CORNER PULLEY



▶ THERMO BULB

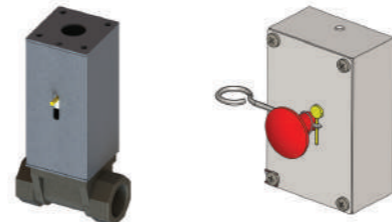

▶ SHUT-OFF GAS VALVE ▶ MANUAL ACTIVATION



▶ PRESSURE TRANSMITTER

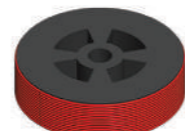

▶ DETECTION TUBE



▶ PRESSURIZED CYLINDER



- ▶ Defender is easy to install, use and maintain.
- ▶ **Defender M** is apt for high temperature, intensive use and tough applications.
- ▶ **Defender P** is apt for fast detection in low temperature environments.

▶ **Defender has an alternative option for applications of all sizes:**

- ▶ **DP 4** : 4 Flow system
- ▶ **DP 8** : 8 Flow system
- ▶ **DM12** : 12 Flow system
- ▶ **DP16** : 16 Flow system
- ▶ **DM18** : 18 Flow system



- ▶ The performance-enhanced nozzles in Defender's technology have a wider range and extinguishing performance than its opponents.
- ▶ Defender's nozzles are different from its opponents with its non-clogging feature. The total cost of the system is low with a small capacity system cylinder, minimum number of nozzles and less pipe line.
- ▶ Defender's system cylinder is continuously pressurized. Maintenance and refilling costs are economical.
- ▶ Defender's activation mechanism can be operated both automatically and manually



- ▶ **Wide and fast detection range:**
- ▶ 130°C
- ▶ 141°C
- ▶ 182°C
- ▶ 260°C



- ▶ The performance of the system has been tested and certified by **LPCB** according to **LPS 1223**.
- ▶ The system and production quality is constantly checked by **BRE Global Certification**.

▶ **WIDE NOZZLE PROTECTION AREA**

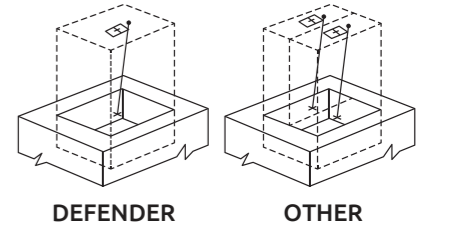

DEFENDER OTHER

▶ **AUTOMATIC / MANUAL ACTIVATION**



▶ PRESSURIZED CYLINDER



▶ THERMO BULB

